

Product Characteristics:

- ❖ Ultra Bright Brightness
- ❖ 5mm Diameter Circular Shape Package
- ❖ General Purpose Lead
- ❖ Highly Reliable

Shape and Size:

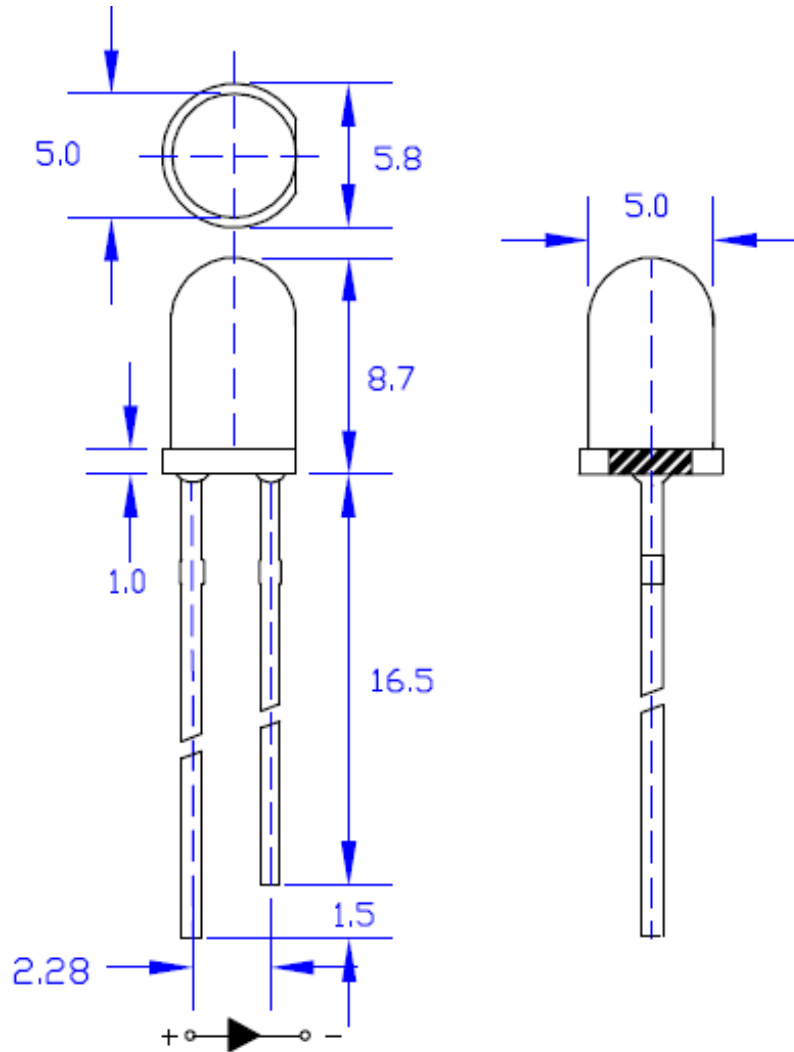

Part No.
(产品编号)

5AG2SC

Emitting Color
(发光颜色)

Green
(绿色)

Notes:

1. All dimensions are in millimeter.
2. Tolerance is $\pm 0.25\text{mm}$ unless otherwise noted.
3. Lead spacing is measured where the leads emerge from the package.

Absolute Maximum Ratings at Ta=25°C

Parameter (项目)	MAX 最大	Unit 单位
Power Dissipation (功率消耗)	70	mW
Continuous Forward Current (直流驱动电流)	20	mA
Reverse Voltage (反向电压)	5	V
Operating Temperature Range (工作温度)	-30°C To +85°C	
Storage Temperature Range (贮存温度)	-40°C To +100°C	
Lead Soldering Temperature (4mm(0.157")From Body) (焊接温度)	260°C for 3 seconds	

Electrical Optical Characteristics at Ta=25°C

Parameter 参数名称	Symbol 符号	Min 最小.	Typ 标准	Max. 最大	Unit 单位	Test Condition 测试条件
Luminous Intensity 发光亮度	I _v	15000	-----	25000	mcd	IF=20mA
Viewing Angle 发光角度	2θ _{1/2}	-----	30	-----	Deg	IF=20mA
Peak Wavelength 峰值波长	λ _p	515	-----	525	nm	IF=20mA
Forward Voltage 正向电压	V _F	3.0	-----	3.6	V	IF=20mA
Reverse Current 反向漏电流	I _R	-----	-----	5	μA	VR=5V

Notes:

1. Luminous intensity is measured with a light sensor and filter combination that approximates the CIE eye-response curve .
2. 2θ_{1/2} is the off-axis angle at which the luminous intensity is half the axial luminous intensity .

Typical Electro-Optical Characteristic Curves

(25°C Ambient Temperature Unless Otherwise Noted)

Relative Intensity VS. Wavelength

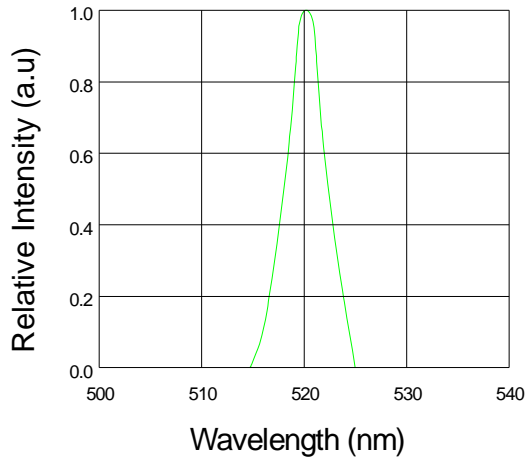

Forward Current VS. Forward Voltage

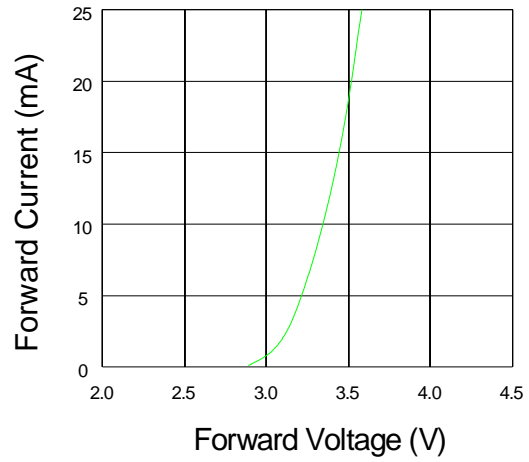

Relative Intensity VS. Ambient Temp

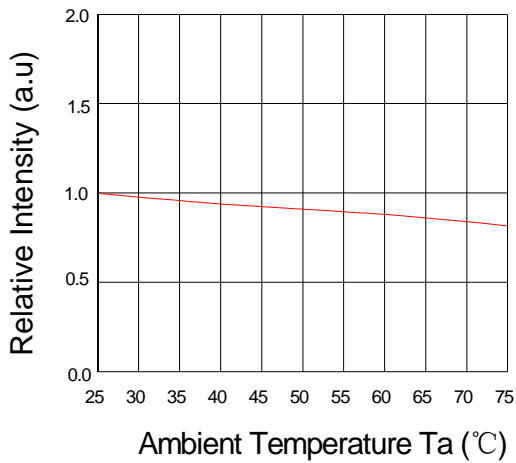

Forward Current VS. Relative Intensity

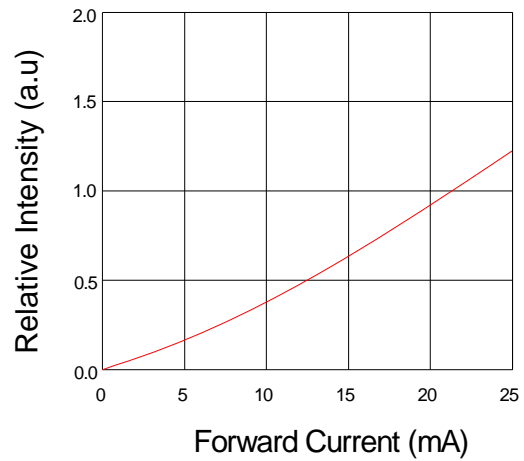

Forward Current VS. Ambient Temp.

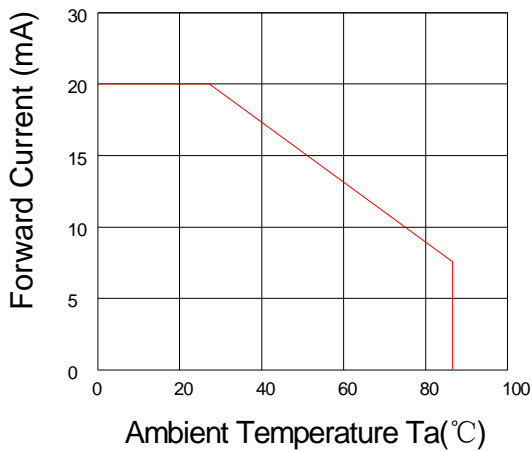

Radiation Characteristics

