

## 1、描述Description:

- Package ( L/W/H ) : 5.0 × 5.0 × 1.6mm
- Color : Ultra Bright Green
- Lens: Water Clear Flat Mold
- EIA STD Package
- Meet ROHS, Green Product
- Compatible With SMT Automatic Equipment
- Compatible With Infrared Reflow Solder And Wave Solder Process

## 2、外形尺寸 Dimensions

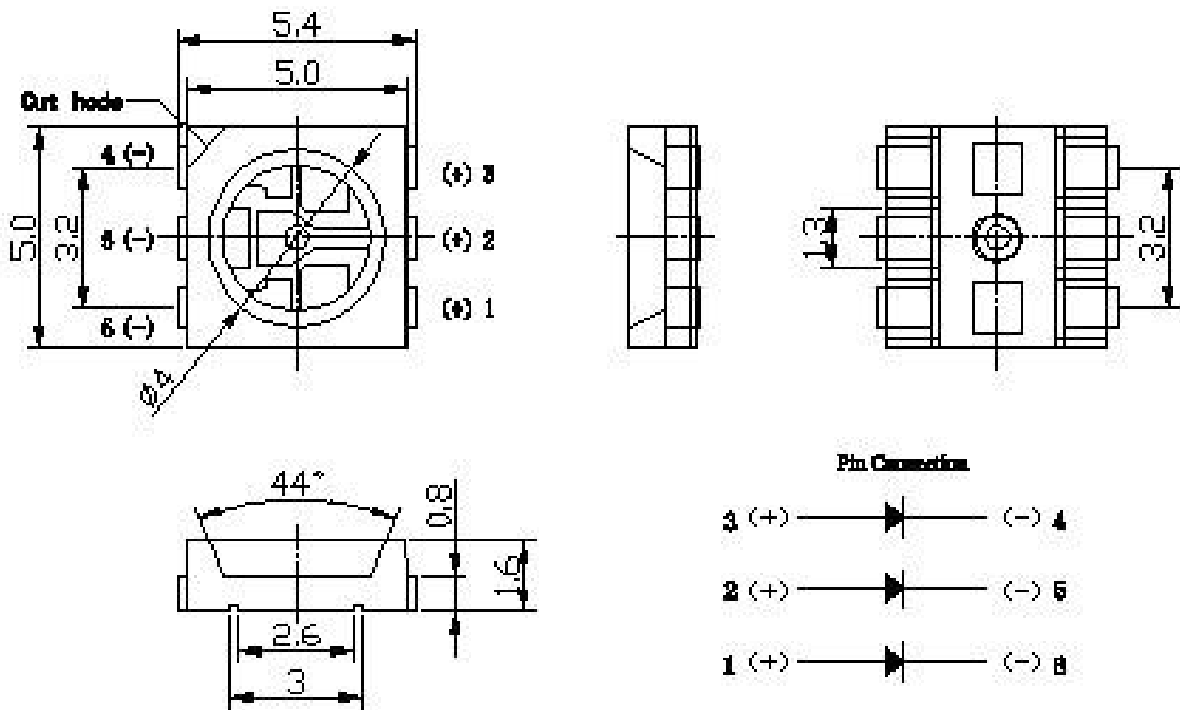

单位(Units):毫米(mm)

Part No. (产品编号)	Lens Color (胶体颜色)	Emitting Color (发光颜色)
VH-5050GVC	Water Clear (无色透明)	Green(绿色)

### Notes:

- 1、 All dimensions are in millimeters ;
- 2、 Tolerance is  $\pm 0.10$  mm unless otherwise noted.

### 3、 光电特性 Electrical / Optical characteristics

#### (1) 最大限度额定值 Absolute Maximum Ratings (TA=25° C)

Parameter	Symbol	Rating	Unit
功率消耗Power Dissipation	Pd	500	mW
正向峰值电流Pulse Forward Current (1/10 Duty Cycle, 0.1ms Pulse Width)	IFP	200	mA
直流正向电流DC Forward Current	IF	60	mA
反向电压Reverse Voltage	VR	15	V
工作温度Operating Temperature	Topr	- 25° C ~ + 85° C	° C
贮藏温度Storage Temperature	Tstg	+40° C ~ + 60° C	° C
焊接温度Soldering Temperature	Tsol	240°C for 3 sec.	

#### (2) 光电参数Initial Electrical/Optical Characteristics (TA=25° C)

项目 Item	符号 Symbol	颜色 Color	最小值 Min.	规格值 Typ	最大值 Max.	单位 Units	测试条件 Test Condition
发光强度 Luminous Intensity	IV	R	2200	...	2400	Mcd	IF=60mA
主波长 Dominate Wavelength	$\lambda D$	R	...	522	...	Nm	IF=60mA
峰值波长 Peak Wavelength	$\lambda p$	R	519	...	525	Nm	IF=60mA
半波宽度 Spectral Line Half- Width	$\Delta \lambda$	R	...	...	...	Nm	IF=60mA
正向电压 Forward Current	VF	R	3.0	...	3.4	V	IF=60mA
反向电流 Reverse Current	IR	R	...	...	10	$\mu A$	VR=5V
发光角度 Viewing Angle	2 $\theta$ 1/2	...	120	...	140	Deg	IF=60mA

Notes:

- 1、 Luminous intensity is measured with a light sensor and filter combination that approximates the CIE eye-response curve.
- 2、  $\theta$ 1/2 is the off-axis angle at which the luminous intensity is half the axial luminous intensity.
- 3、 The dominant wavelength,  $\lambda d$  is derived from the CIE chromaticity diagram and represents the single wavelength which defines the color of the device.

4、 特性曲线 Characteristic curve

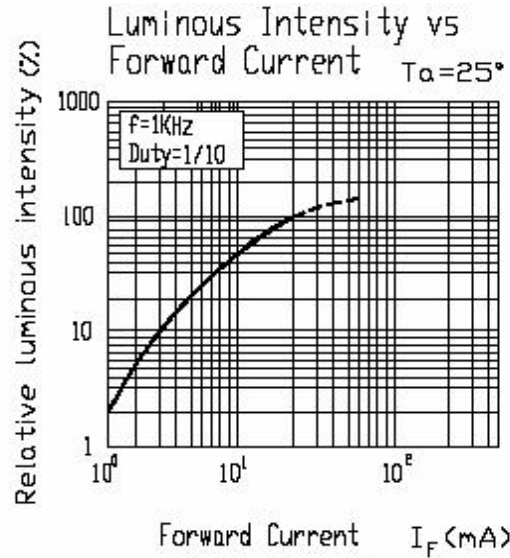
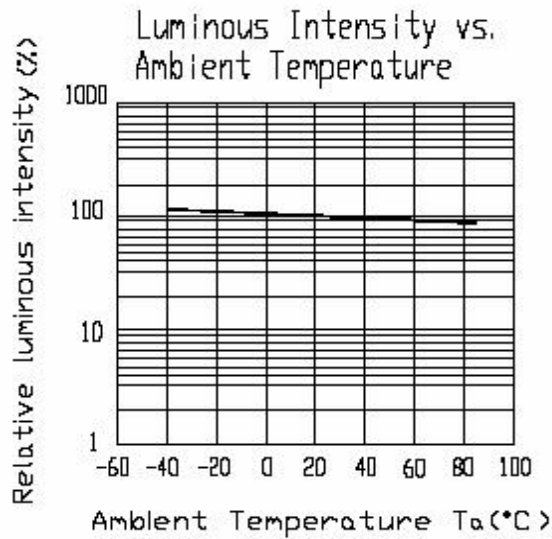
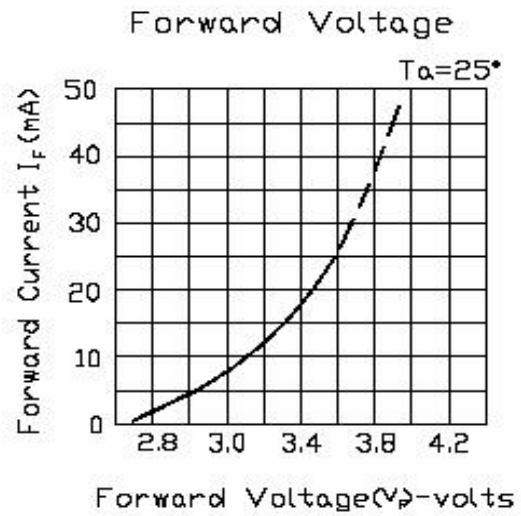
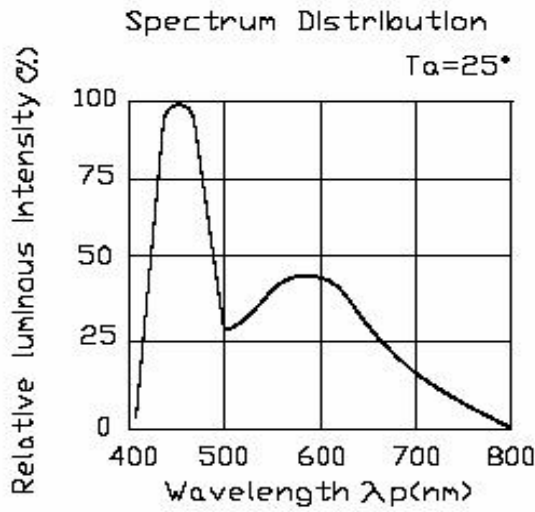

Forward Current Derating Curve

